

STRONGBOX

Our Strongbox enclosure is designed to protect control gear & instrumentation against opportunistic attempts to vandalise or steal valuable equipment.

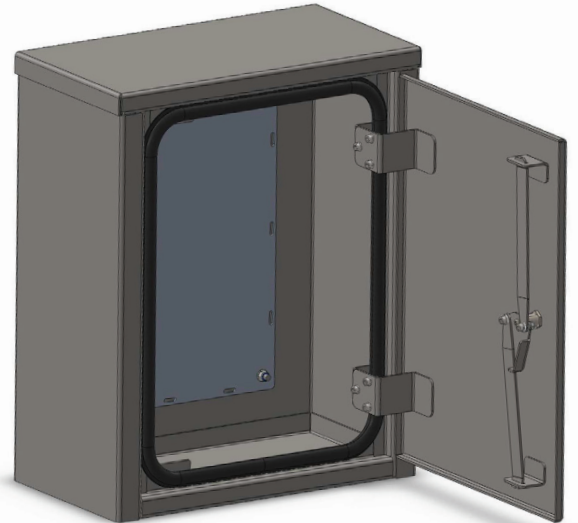

LEVEL
2

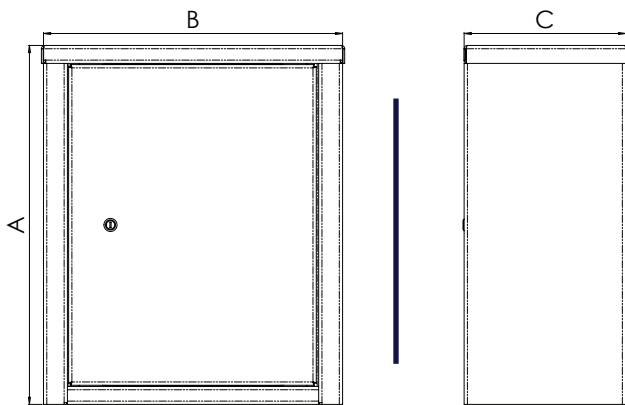

The strongbox is manufactured from Mild steel & Stainless steel options, Covered with a high-strength corrosive coating & finished with hardened paint coating. These Enclosures are lockable with the option of mechanical or electronic locks. Our enclosures come in 5 different sizes, Customized sizes are available on request. Sold Standard with backplates.

These enclosures are designed for industrial applications and manufactured with high-strength protection against opportunistic attempts to vandalize & damage valuable equipment. Currently available in 3 colours; Grey, Orange & Gunmetal grey. The enclosures can be wall-mounted or pole-mounted.

Features

- Vandal-resistant
- Anti-corrosion coated
- 3 - 5 mm wall thickness
- Watertight design
- 3 point locking system
- Internal Hinges



Designation	Description	Dimension (mm)
A	External	600
B	External	500
C	External	270
D	Door Opening	492
E	Door Opening	366